

12' x 24' PAVILION COVER



1000 Loudermilk Drive Bldg 400 Marietta, GA 30060
Phone: (470) 870-7733

This document is property of Mitchell Metals, LLC. Modifications to this document are prohibited prior written consent from Mitchell Metals, LLC.

STAMP

STYLE:

12'x24' PAVILION COVER

This document is property of Mitchell Metals, LLC. Modifications to this document are prohibited prior written consent from Mitchell Metals, LLC.

ITEM NO.	PART NUMBER	DESCRIPTION
1	6063-T6 Aluminum	Column (See Page 3 for Size)
2	6063-T6 Aluminum	Beam (See Page 3 for Size)
3	6063-T6 Aluminum	4X6 GUTTER
4	6063-T6 Aluminum	6 False Fascia
5	6063-T6 Aluminum	2 x 2 x .250 Square Tube
6	0.080" Aluminum	Welded End Cap
7	Aluminum	Ridge Cap Flashing .040 Thickness
8	Aluminum	3 x 12 x 0.032 Roll Formed Flat Pan
9	Deflector Plate	Deflector Plate
10	Concrete Slab	By Others

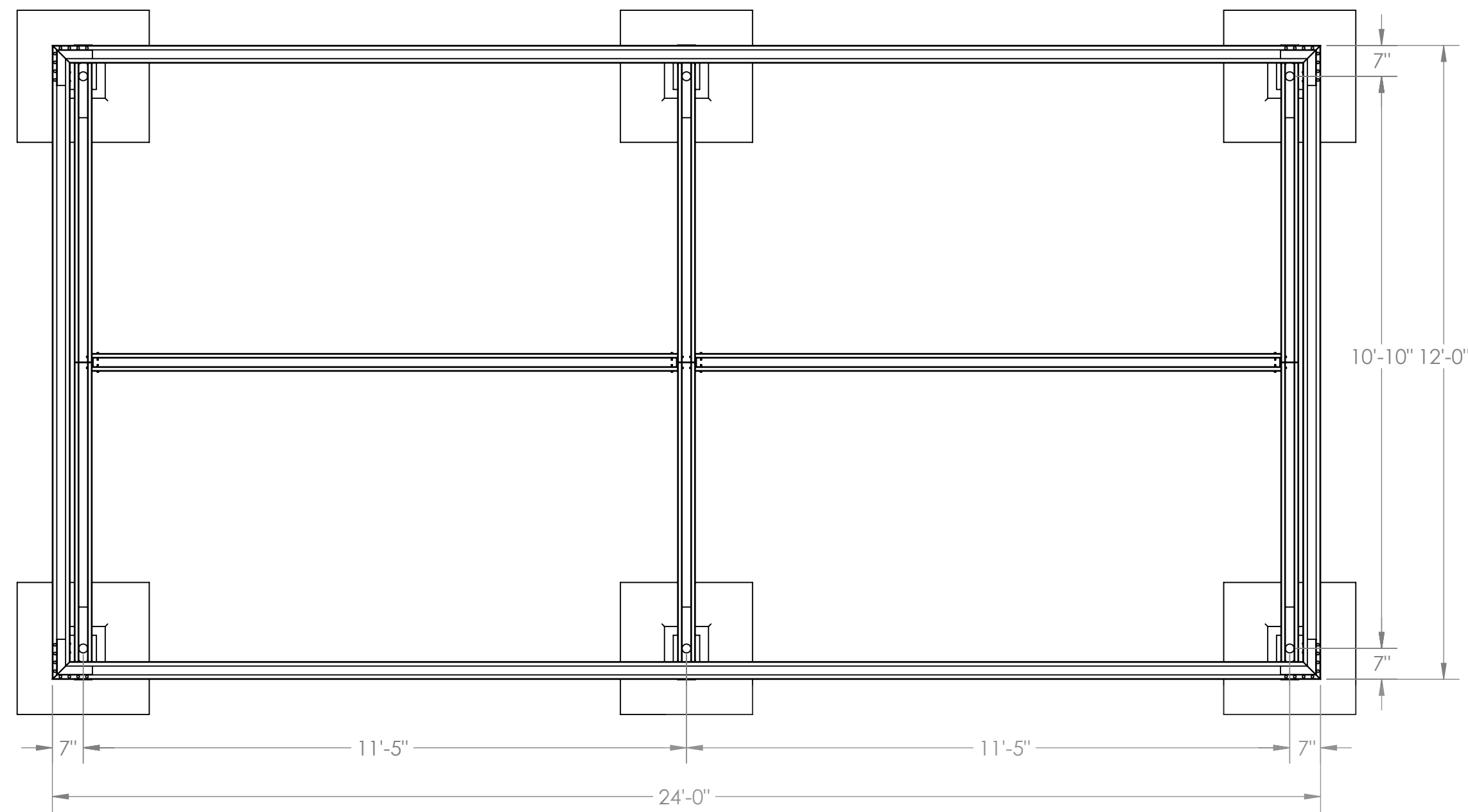

**TOP VIEW - NO DECKING
FRAMING AND GUTTER LAYOUT**

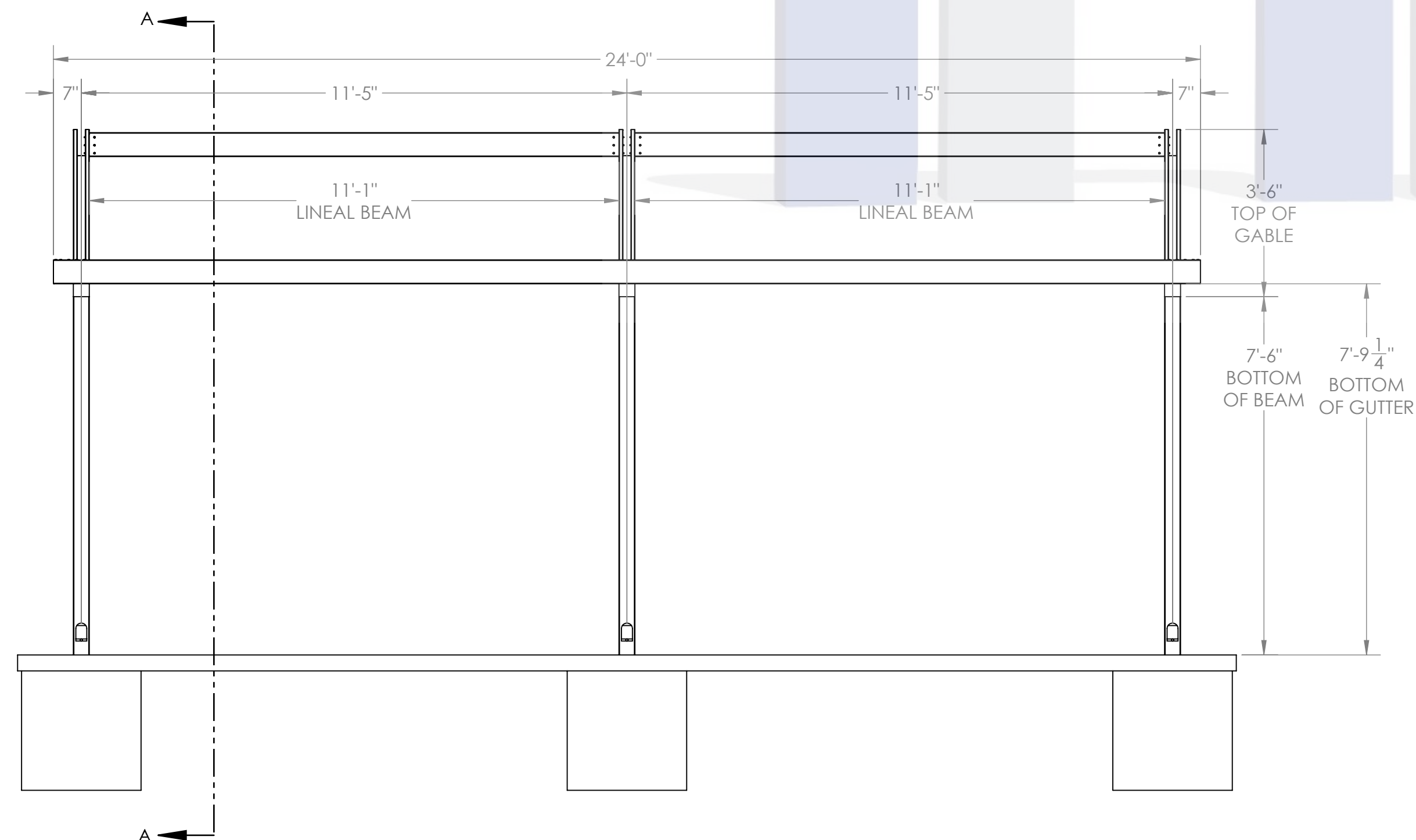

**ELEVATION VIEW
FRAMING AND GUTTER LAYOUT**

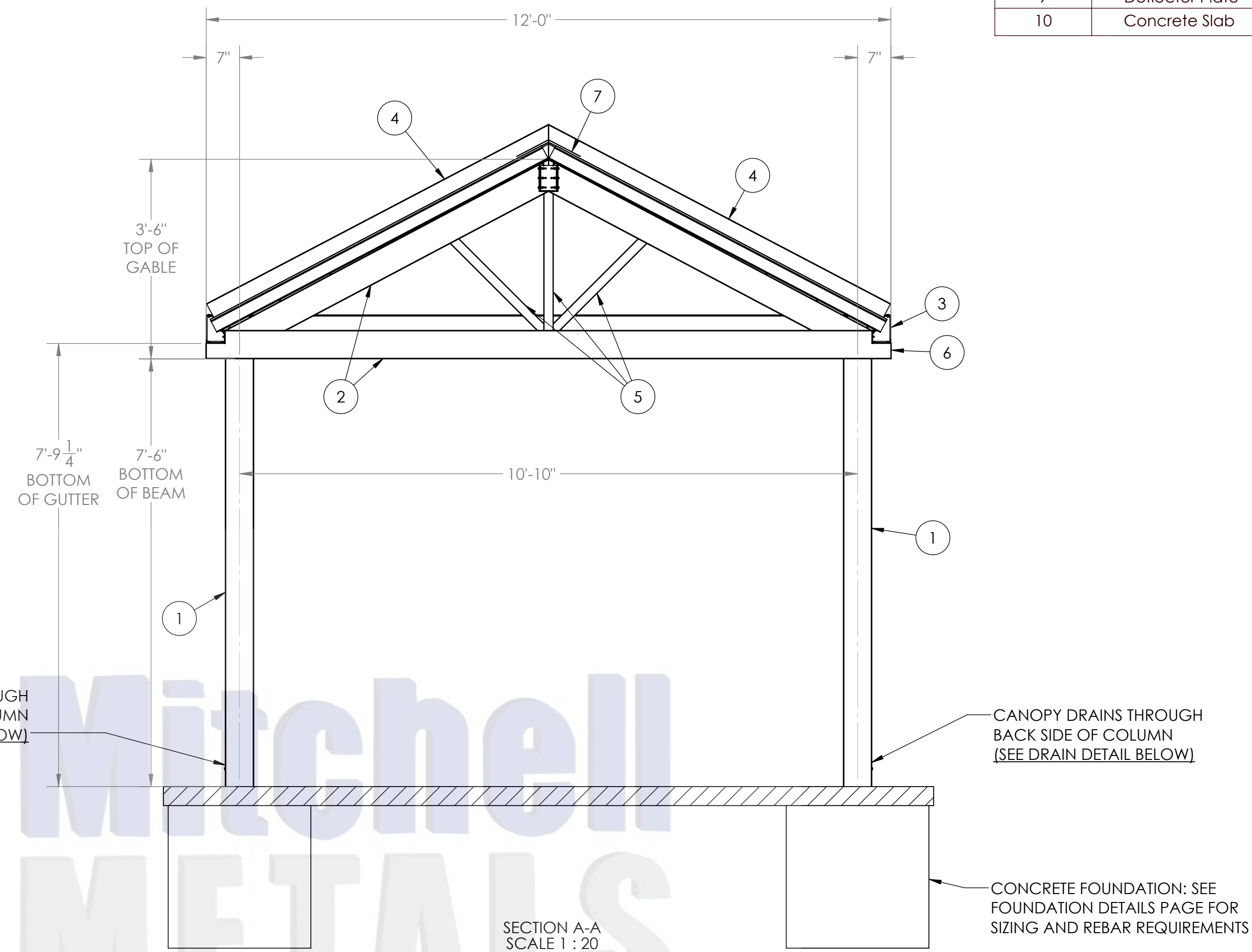

SECTION VIEW

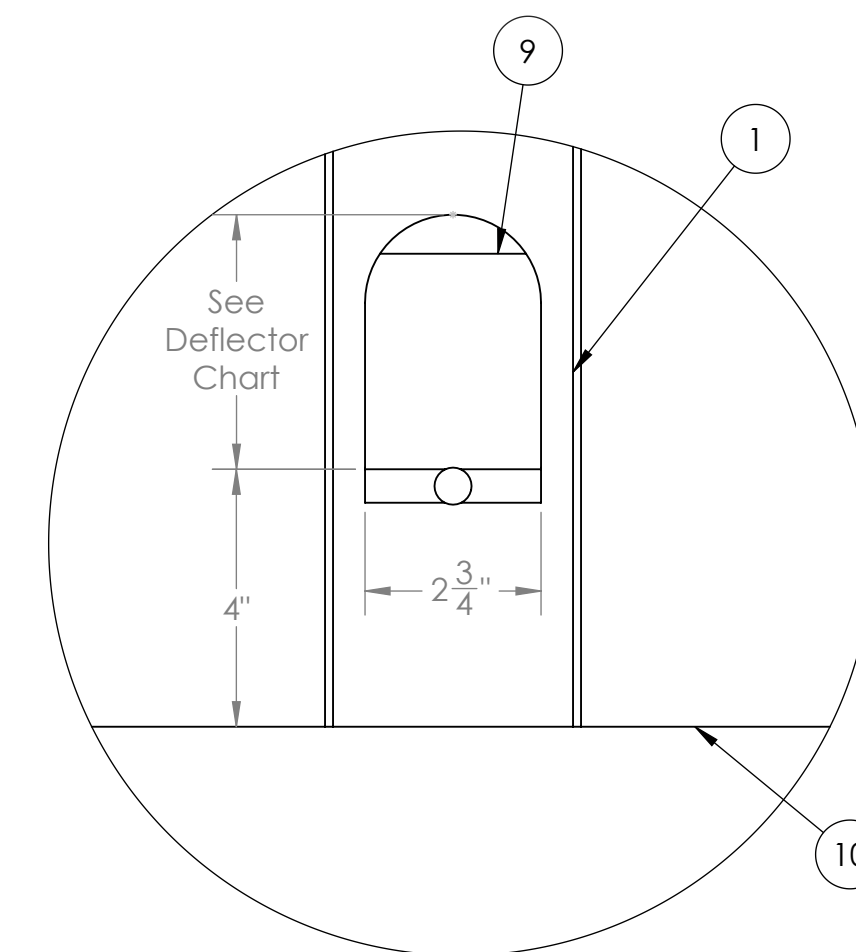

**COLUMN DRAIN
HOLE DETAIL
SCALE 1 : 3**

Deflector Plate Cutout Height	Column Size
4"	4"x6"
6"	6"x6"

STAMP

STYLE:

12'x24' PAVILION COVER

This document is property of Mitchell Metals, LLC. Modifications to this document are prohibited prior written consent from Mitchell Metals, LLC.

View Before Footing and Blockout Installation



Ver antes de instalar la zapata de concreto

GENERAL NOTES:

- Max column height to be 9'-0". Canopy designed at 7'-6" to bottom of beam above finished concrete slab.
- See Foundation Details Page for concrete foundation design based on project location design criteria.
- Minimum footing size is based on 1500 PSF soil condition.
- Adhere to all local building codes, including layout, foundation design and depth (i.e. frost line depth).
- Any canopy lighting required is provided by others and may require additional canopy framing to support.
- Reference 2010 ADA Standards for Accessible Design for concrete pad design.
- **DESIGN CRITERIA:** IBC 2018, ASCE 7-16, ADM 2015, Exposure Category = B, Risk Category = II, Live Load = 20 psf.
 - Wind = 115mph (max), Ground Snow Load = 30psf (max) - 4"x6"x0.150" Columns, 4"x6"x0.125" Beams
 - Wind = 140mph (max), Ground Snow Load = 5psf (max) - 6"x6"x0.150" Columns, 6"x6"x0.130" Beams

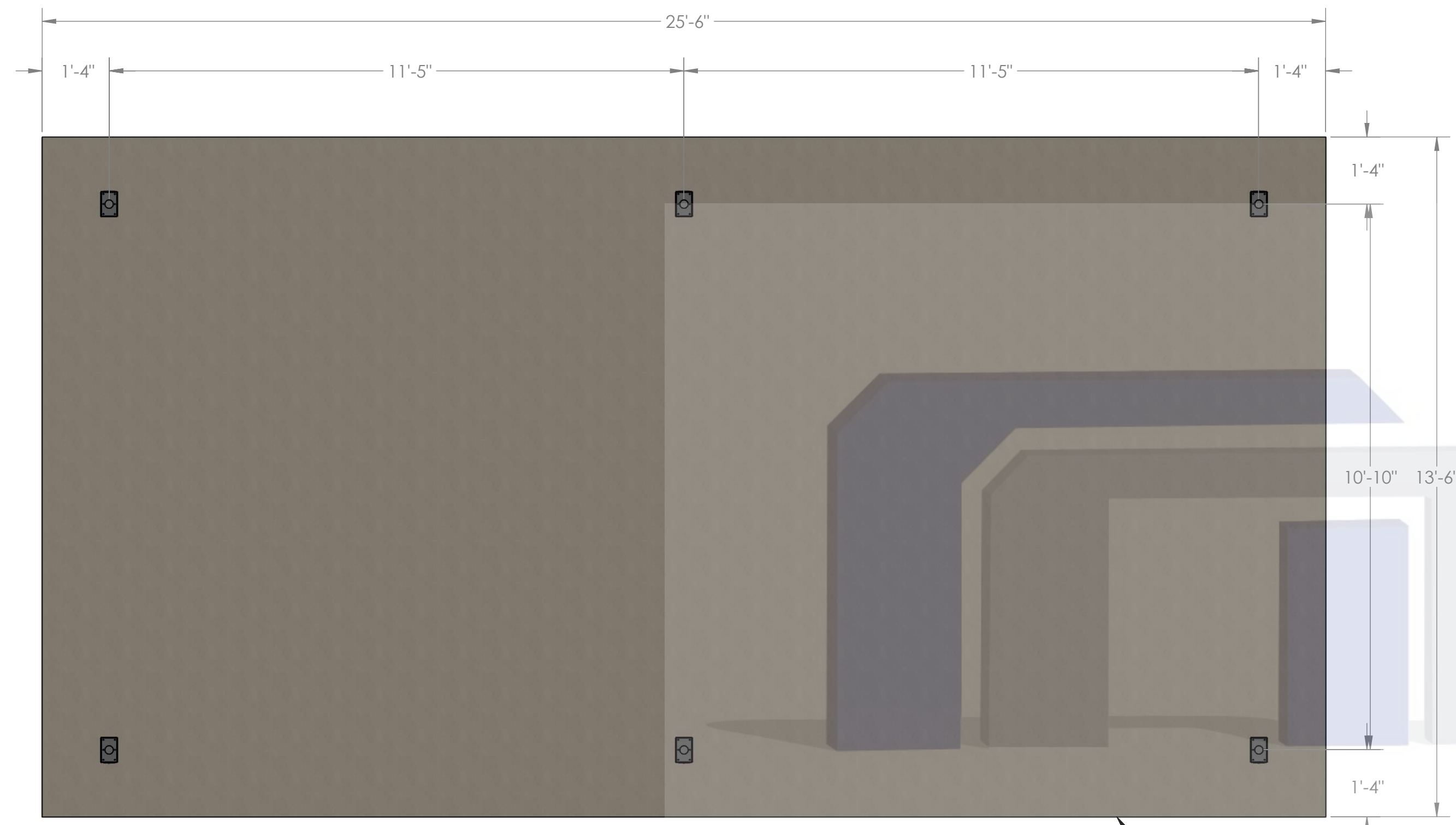

**TOP VIEW
COLUMN/MAILBOX/CONCRETE LAYOUT**

CONCRETE SLAB
(By Others)

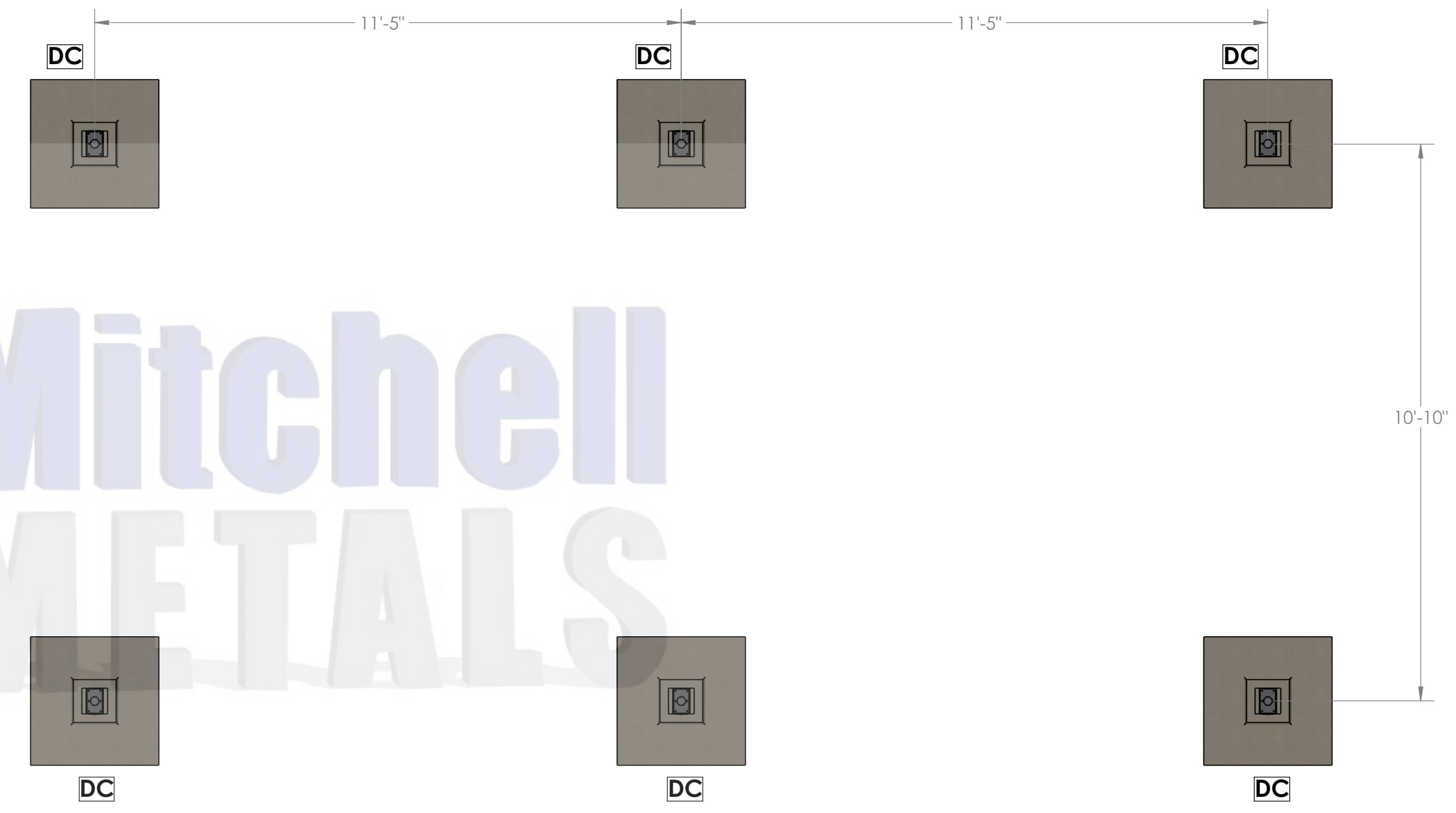

**TOP VIEW
FOOTING/COLUMN LAYOUT**

STYLE: **12'x24' PAVILION COVER**

STAMP

