

PERGOLA



1000 Loudermilk Drive, Bldg 400, Marietta, GA 30060
Phone: (470) 870-7733

This document is property of Mitchell Metals, LLC. Modifications to this document are prohibited without prior written consent from Mitchell Metals, LLC.

STAMP

STYLE:

PERGOLA (12' x 24')

This document is property of Mitchell Metals, LLC. Modifications to this document are prohibited without prior written consent from Mitchell Metals, LLC.

| ITEM NO. | PART NUMBER | DESCRIPTION |
|----------|-----------------|--------------------|
| 1 | 6063-T6 | 4 X 8 GUTTER |
| 2 | 6063-T6 | 6 x 6 x .150 Tube |
| 3 | Aluminum | 2 X 3 X .125 ANGLE |
| 4 | 6063-T6 | 2 x 6 x .090 Tube |
| 5 | 6063-T6 | 6 x 6 x .150 Tube |
| 6 | Deflector Plate | Deflector Plate |
| 7 | Pool Chair | By Others |
| 8 | Pool Side Table | By Others |

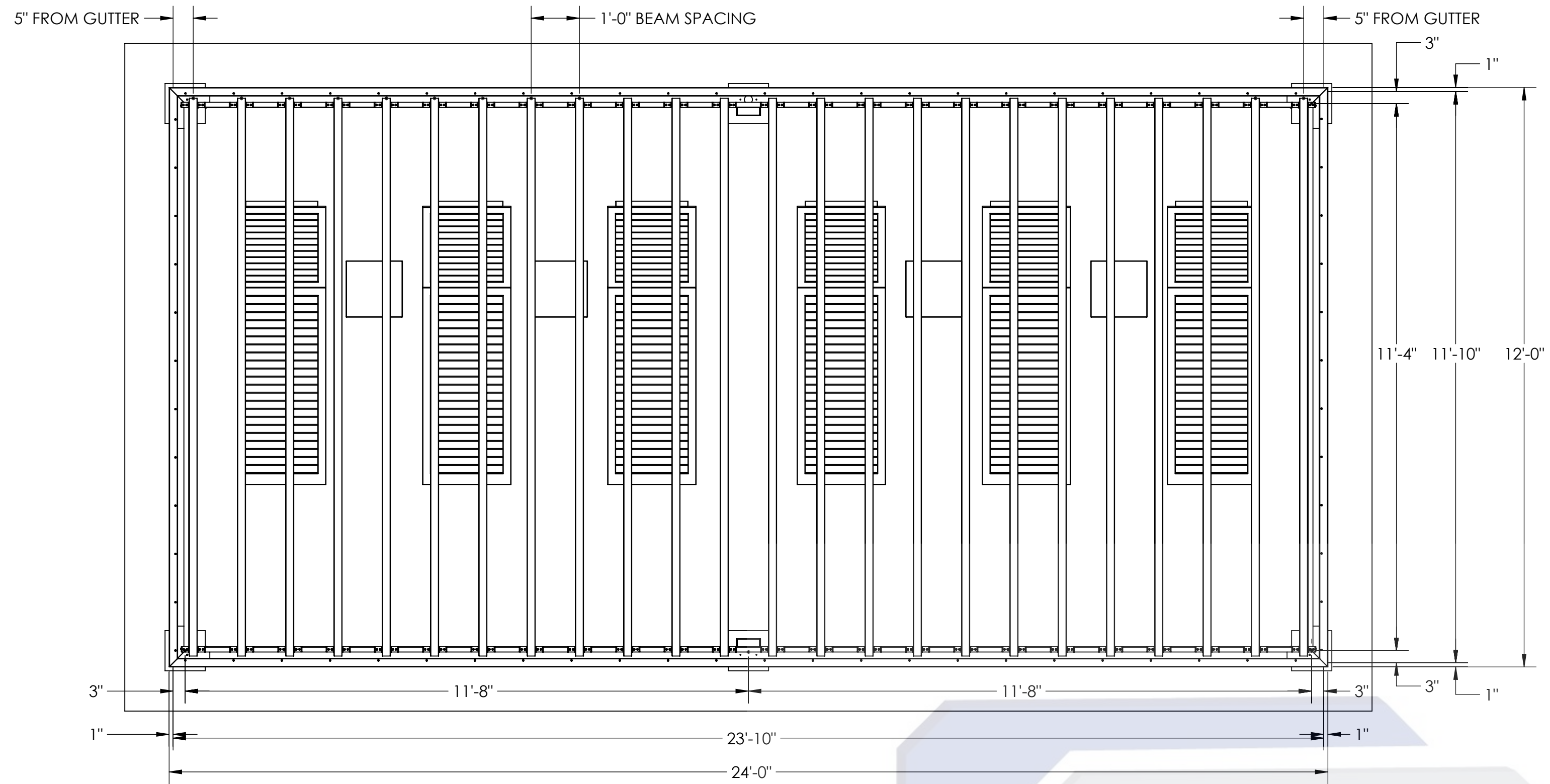

**TOP VIEW - NO DECKING
FRAMING AND GUTTER LAYOUT**

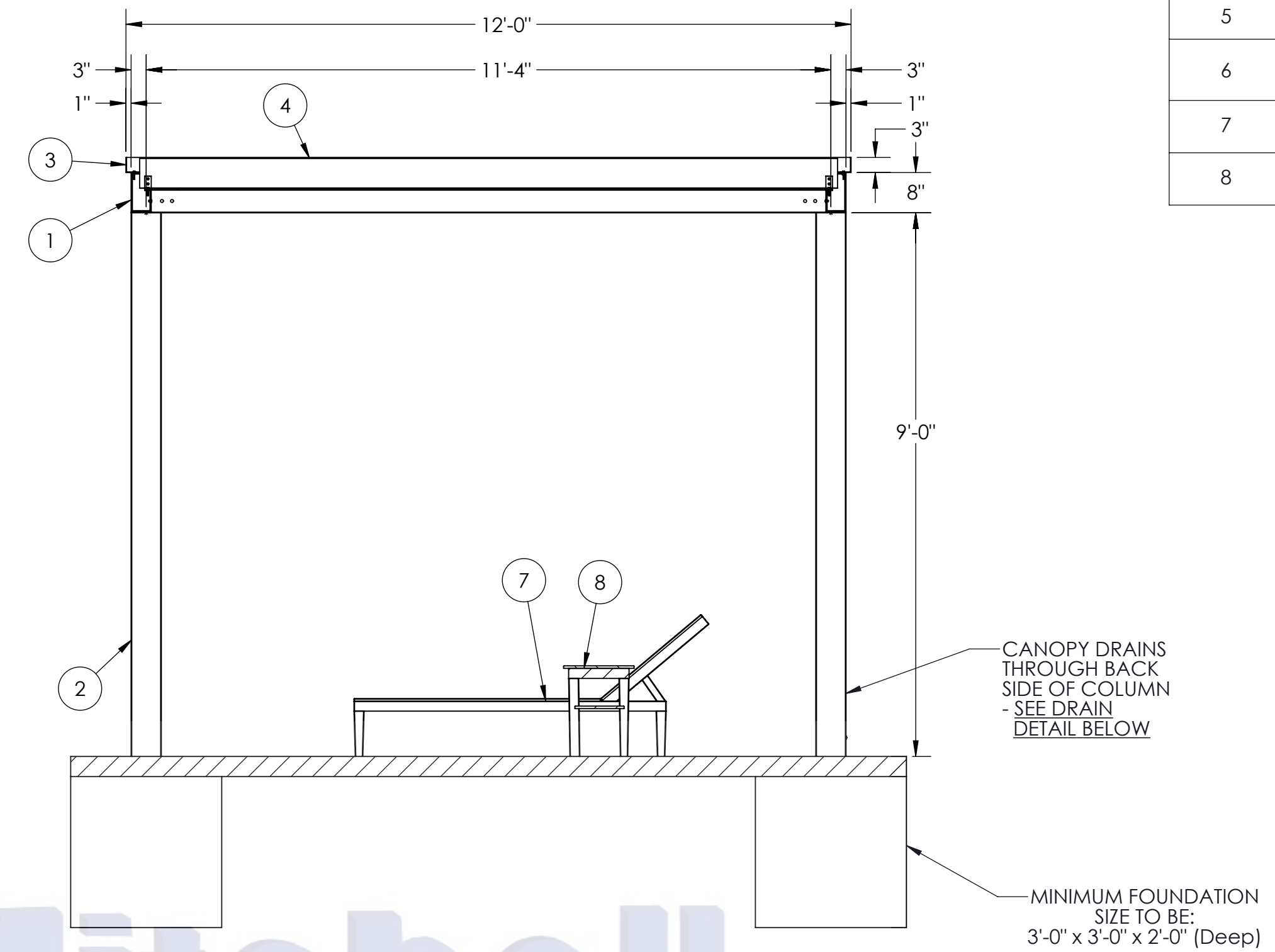

**SECTION A-A
SCALE 1 : 24**

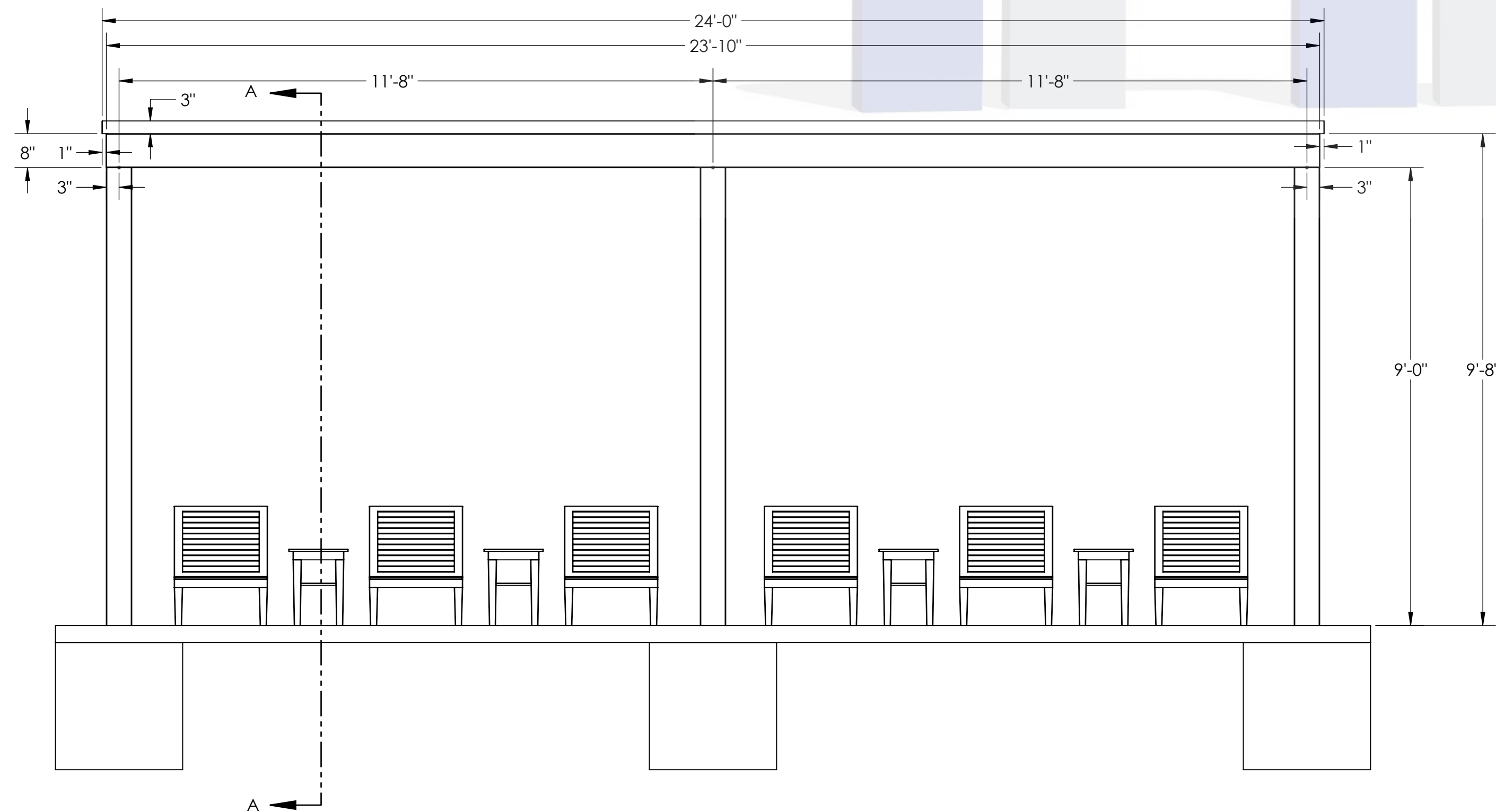

ELEVATION VIEW

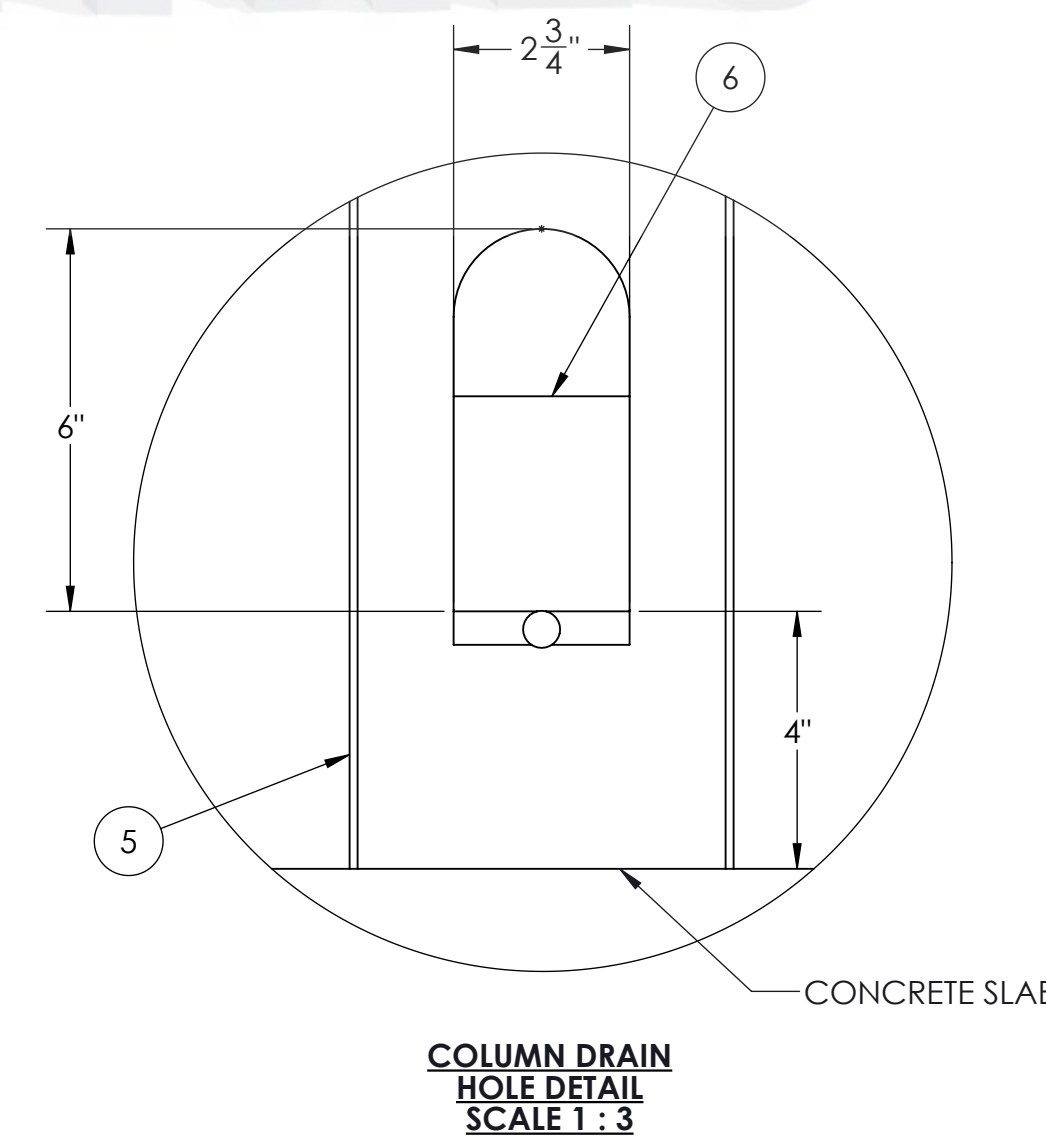

**COLUMN DRAIN
HOLE DETAIL
SCALE 1 : 3**

STYLE: **PERGOLA (12' x 24')**

STAMP

This document is property of Mitchell Metals, LLC. Modifications to this document are prohibited without prior written consent from Mitchell Metals, LLC.

View Before Footing and Blockout Installation



Ver antes de instalar la zapata de concreto

GENERAL NOTES:

- Max column height to be 10'-0". Canopy is designed at 9'-0" to bottom of beam above finished concrete slab.
- See Foundation Details Page for concrete foundation design based on project location design criteria.
- Minimum footing size is based on 1500 PSF soil condition.
- Adhere to all local building codes, including layout, foundation design and foundation depth (i.e. frost line depth).
- Any canopy lighting required is provided by others.
- Reference 2010 ADA Standards or Accessible Design for concrete pad
- **DESIGN CRITERIA:**
 - IBC 2018, ASCE 7-16, ADM 2015, Exposure Category = B, Risk Category = II, Live Load = 20 psf.
 - WIND = 140 mph (max), Ground Snow Load = 5 psf (max)

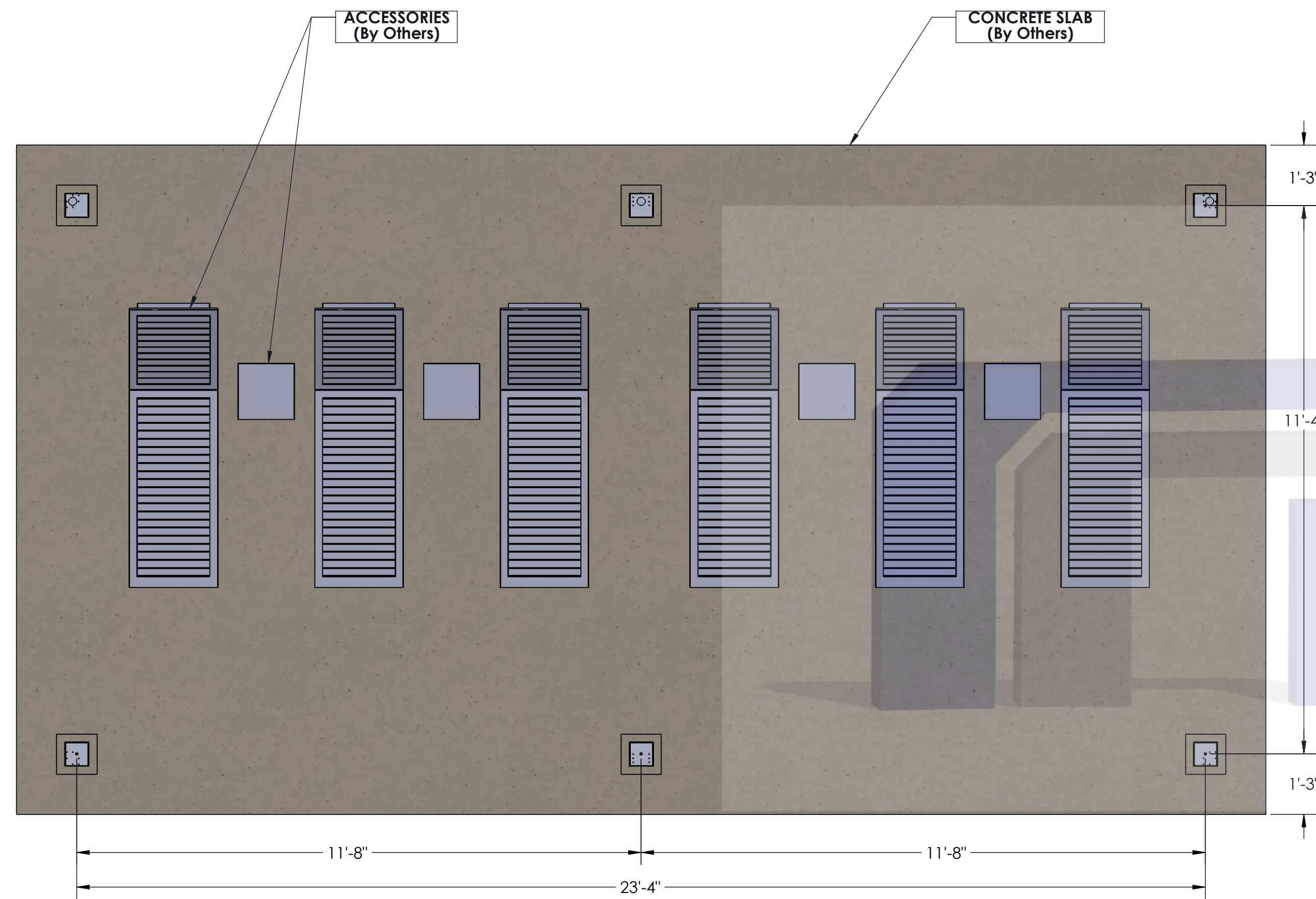

TOP VIEW
COLUMN/BENCH/CONCRETE LAYOUT

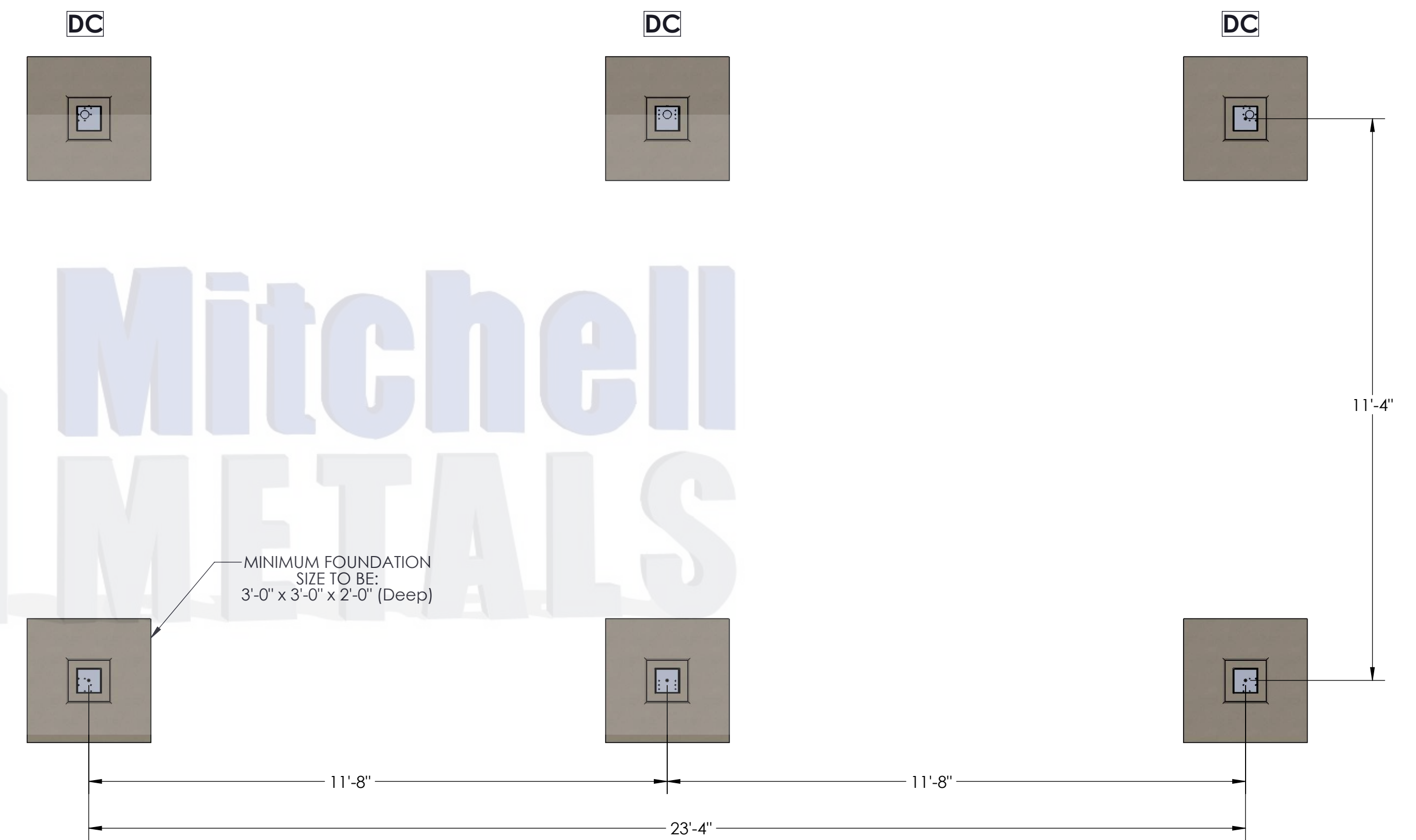

TOP VIEW
FOOTING LAYOUT

STYLE: **PERGOLA (12' x 24')**

STAMP