

ISOMETRIC VIEWS

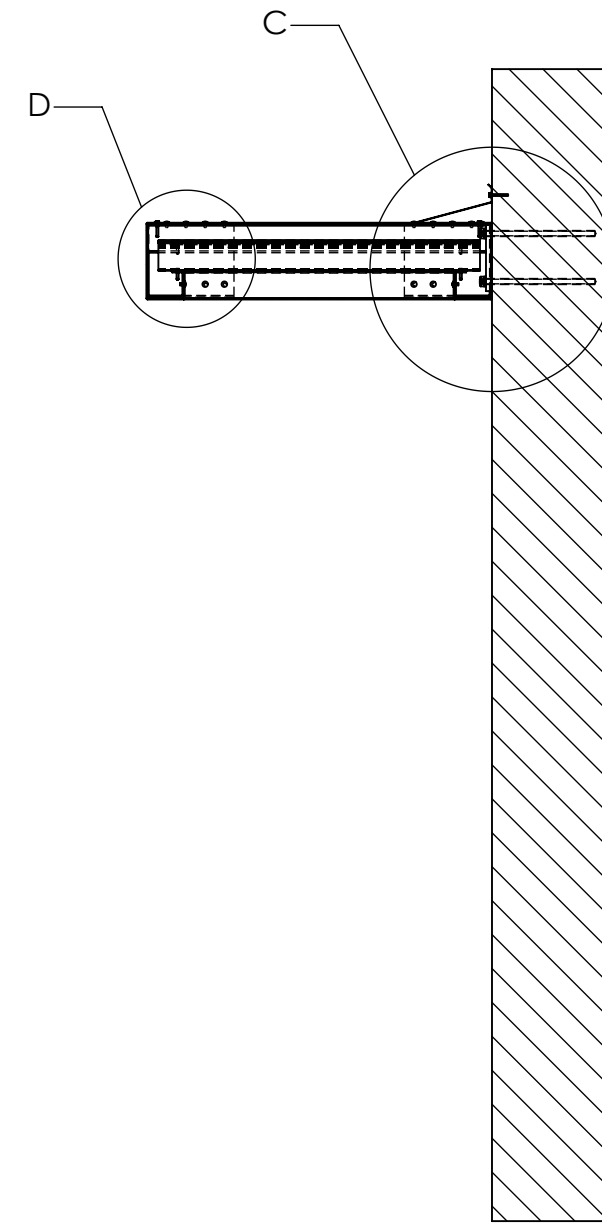

SECTION A-A
SCALE 1 : 20

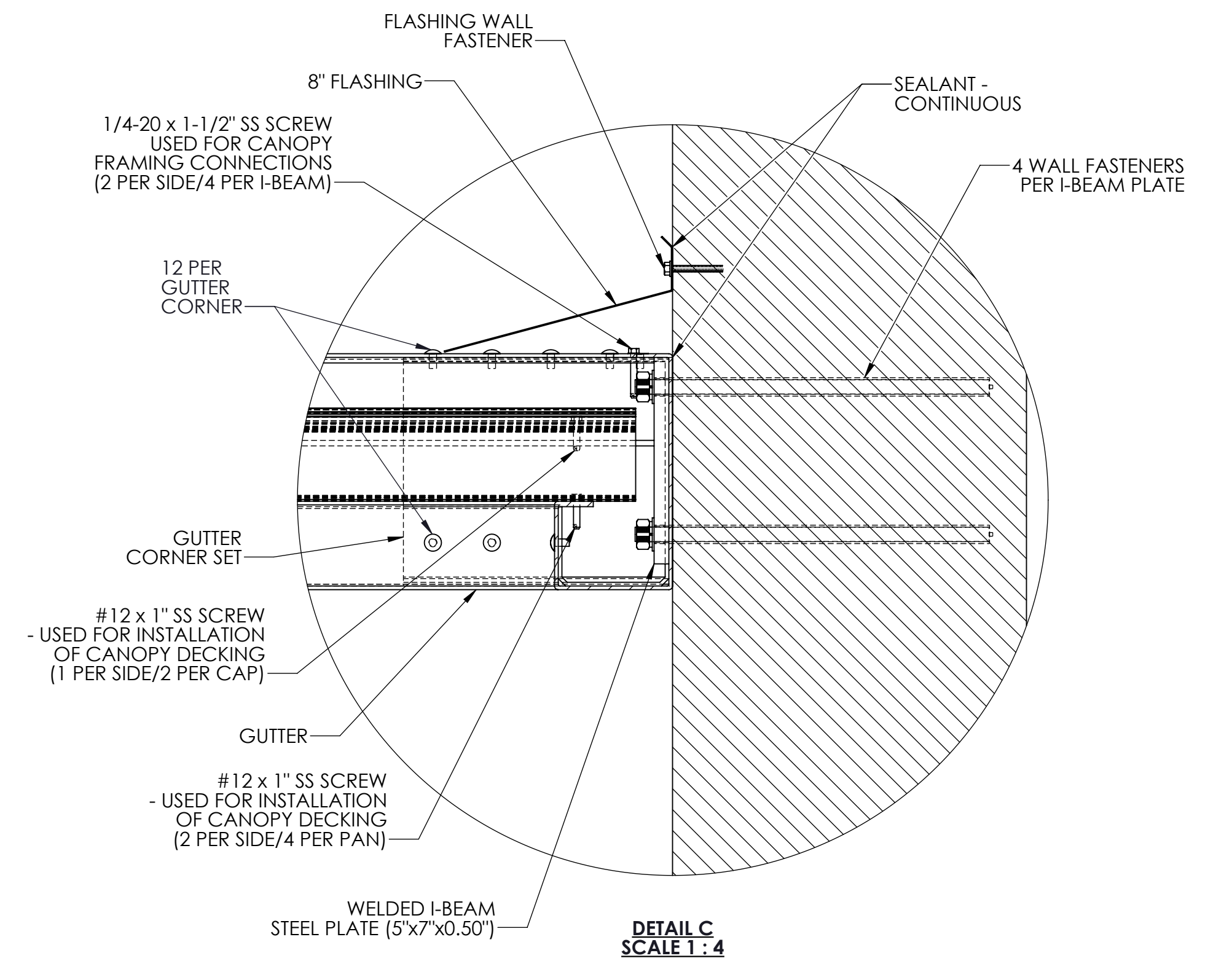

DETAIL C
SCALE 1 : 4

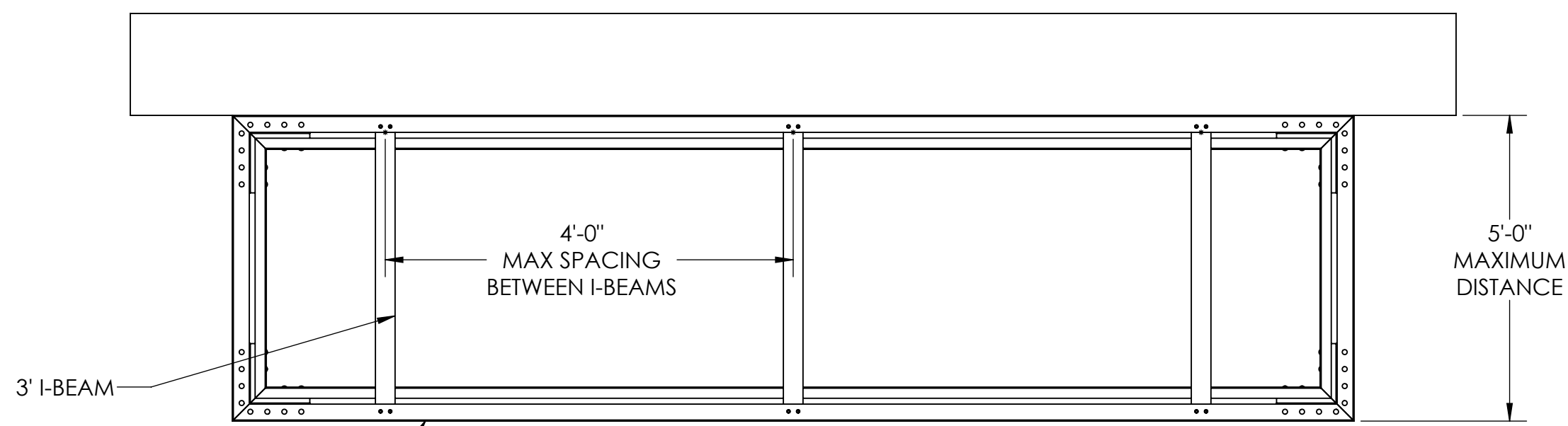

TOP VIEW (NO DECKING)

SECTION VIEW

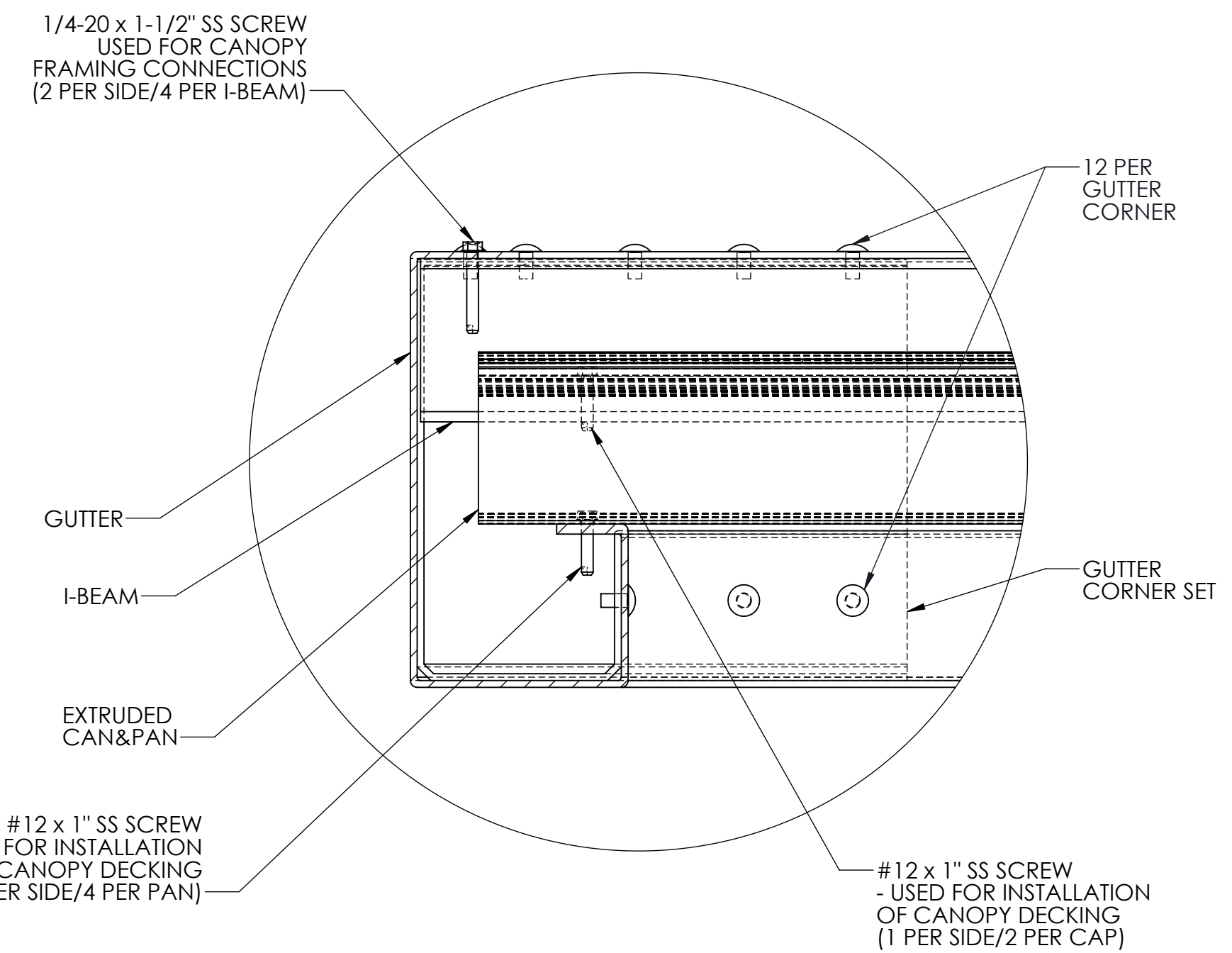

DETAIL D
SCALE 1 : 2.5

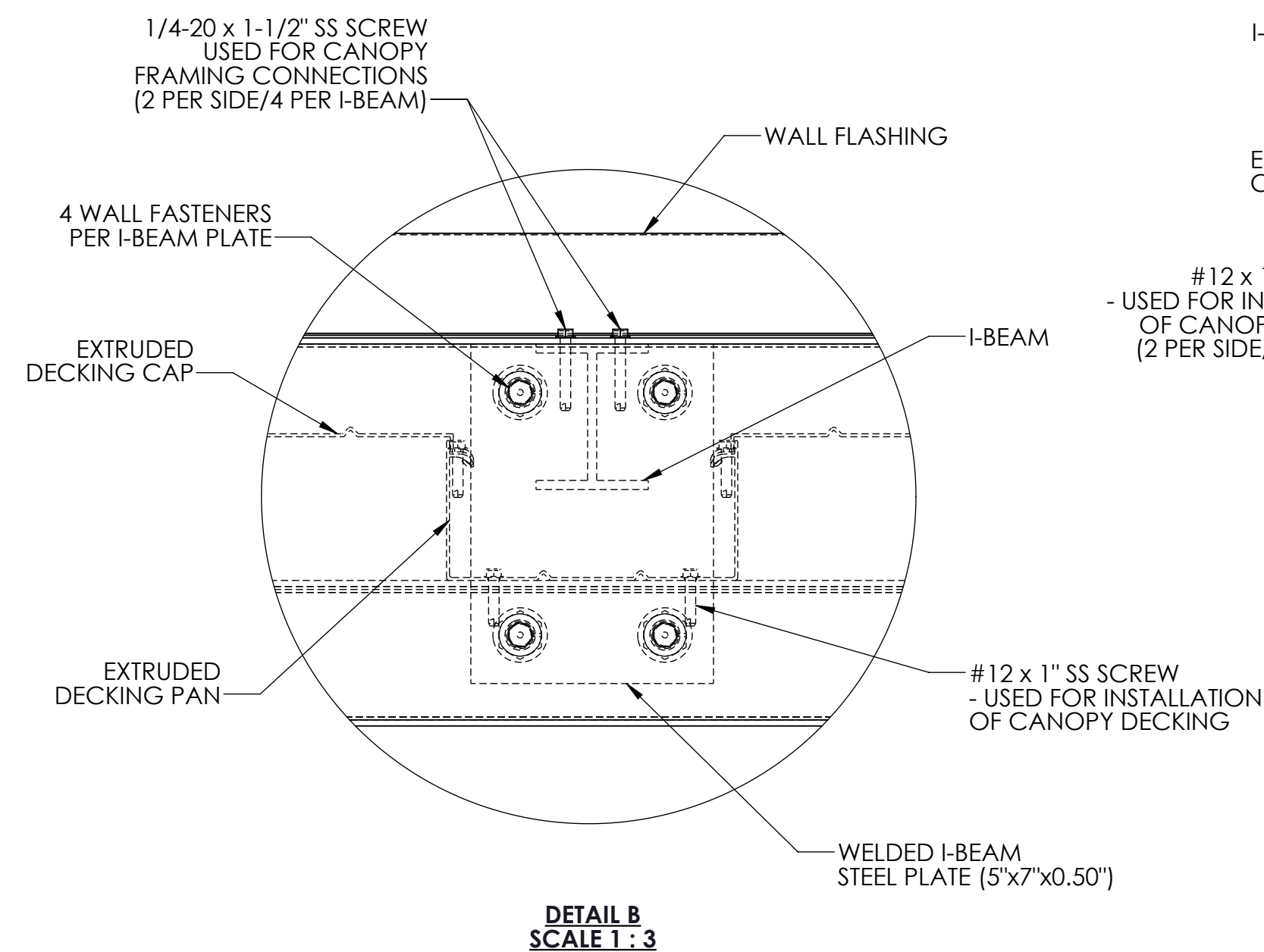

DETAIL B
SCALE 1 : 3

SPECIFICATIONS
Section 107300 - Aluminum Walkway Covers

1.01 General Description of Work:
A. Work in this section shall include design and fabrication of pre-engineered aluminum canopies.
B. Canopies are to be fabricated and installed according to approved canopy drawings.

1.02 Design Criteria:
A. International Building Code 2015
B. ASCE 7-10
C. Aluminum Design Manual 2015
D. Local governing codes and standards for site location

1.03 Materials:
A. All materials shall be extruded aluminum unless indicated otherwise on canopy drawings.
B. Material size shall meet or exceed the design criteria on 1.02

1.04 Finishes:
A. Factory applied baked enamel to comply with AAMA 2603.
B. Color selected from manufacturer's standard colors.

1.05 Manufacturers:
A. Mitchell Metals, LLC - www.MitchellMetals.net - 770-431-7300
B. Dittmer - www.Dittdeck.com - 407-699-1755
C. See Specifications 2.1-C for conditions of equivalent systems by other manufacturers

- NOTES:**
- CANOPY PROJECTION FROM WALL SHOULD NOT EXCEED 5'-0".
 - ALL FASTENERS TO BE 300 SERIES STAINLESS STEEL OR ALUMINUM (Rivets)

TYPE:	I-BEAM SUPPORTED CANOPIES
STYLE:	FLOATING ENTRANCE CANOPY
DATE: 10/29/2025	SHEET 1 OF 1

STAMP